



High-Efficiency Deflection and High-Voltage Circuits for Short Metal Kinescope RCA-16GP4

This Note describes a magnetic-deflection and high-voltage circuit of improved efficiency intended for use with the short metal kinescope RCA-16GP4. Although the deflection power required for the 70-degree deflection angle of the 16GP4 is nearly twice the value needed for the 53-degree angle of other magnetic-deflection kinescopes operating at the same anode voltage, the efficiency of this new circuit has been sufficiently increased so that the power input for both horizontal- and vertical-deflection circuits is slightly less than the power required by the horizontal-deflection amplifier alone in many present systems for deflection angles of 53 degrees. The total power needed to develop maximum anode voltage of 14,000 volts (no load) and full scanning through an angle of 70 degrees is between 40 and 45 watts with a B-supply voltage of 350 volts. The efficiency of many systems now used is such that nearly 80 watts at over 400 volts would be needed to satisfy these increased deflection requirements.

Driving Voltage Considerations

The high-efficiency circuit is shown in Fig.1. Its horizontal-deflection circuit uses a single RCA-6CD6-G as the horizontal-power-output tube. The amplitude and typical waveform of the grid-driving voltage, as obtained from a conventional horizontal oscillator circuit of the discharge type, is shown in Fig.2. In order that circuit efficiency be maintained, the 6CD6-G must be cut off rapidly and kept cut off during the retrace interval. The rapidity of cutoff is helped by using a peaking resistor in series with the charging capacitor to increase the negative swing of the grid driving voltage. If additional negative driving voltage is required to maintain cutoff throughout the retrace interval, feedback peaking may also be used. A negative pulse suitable for feedback peaking may be obtained from terminal 1 of the horizontal-deflection-output transformer when the connection between the width control and terminal 2 of the transformer is grounded, as shown in Fig.1.

When the driving voltage for the 6CD6-G is obtained from a combined blocking-oscillator-discharge-tube circuit, cutoff is usually rapid

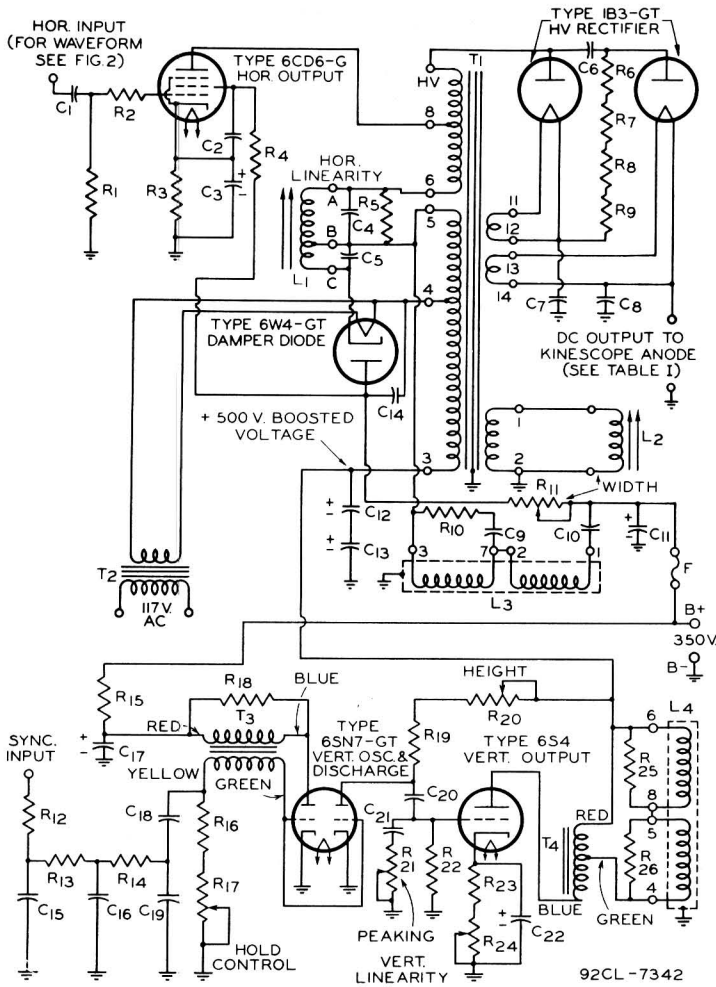

- C1: 0.01 μ f, 600 volts
- C2: 0.25 μ f, 400 volts
- C3: 4 μ f, 50 volts, electrolytic
- C4: 0.03 μ f, 400 volts
- C5: 0.1 μ f, 400 volts
- C6 C7: 500 μ f, 10 kilovolts
- C8: 500 μ f, 20 kilovolts
- C9: 47 μ f, 1500 volts
- C10: 0.1 μ f, 400 volts
- C11: 20 μ f, 400 volts, electrolytic
- C12 C13: 20 μ f, 300 volts, electrolytic
- C14: 100 μ f, rated for 2500 peak pulse volts. Specific value should be selected to give retrace time of about 7.5 microseconds.
- C15 C16 C18 C19: 0.005 μ f, 400 volts
- C17: 4 μ f, 400 volts, electrolytic
- C20: 0.25 μ f, 600 volts
- C21: 0.05 μ f, 600 volts
- C22: 100 μ f, 50 volts, electrolytic
- F: Fuse, 0.25 ampere, 500 volts
- L1: Horizontal Linearity Control RCA-209R1
- L2: Width Control, RCA-208R1
- L3: Horizontal Deflecting Coils of Deflecting Yoke RCA-206D1
- L4: Vertical Deflecting Coils of Deflecting Yoke RCA-206D1
- R1: 250000 ohms, 0.5 watt
- R2: 100 ohms, 0.5 watt
- R3: 300 \pm 5% ohms, 10 watts
- R4: 10000 ohms approx., 3 watts. Value should be sufficient to limit 6CD6-G grid-No.2 input to 3 watts.
- R5: 1000 ohms, 1 watt
- R6 R7 R8 R9: 500000 ohms, 1 watt
- R10: 1000 ohms, 0.5 watt
- R11: Alternate Width Control, 200 ohms, 10 watts, wire-wound potentiometer
- R12 R13 R14: 8200 ohms, 0.5 watt
- R15: 100000 ohms, 0.5 watt
- R16 R19: 1 megohm, 0.5 watt
- R17: Vertical Hold Control, 1 megohm, 0.5 watt, potentiometer
- R18: 10000 ohms, 0.5 watt
- R20: Height Control, 3 megohms, 1 watt, potentiometer
- R21: Vertical Peaking Control, 5000 ohms approx., 0.5 watt. Fixed resistance may be used after needed value has been determined with rheostat.
- R22: 2.2 megohms, 0.5 watt
- R23: 820 ohms, 1 watt
- R24: Vertical Linearity Control, 3000 ohms, wire-wound potentiometer
- T1: Horizontal-Deflection-Output and High-Voltage Transformer, RCA-218T1
- T2: Heater Transformer insulated for 3 kilovolts
- T3: Vertical Blocking Oscillator Transformer, RCA-208T9
- T4: Vertical-Deflection-Output Transformer, RCA-222T1

TABLE I

Kinescope Anode Microamperes	DC Output Volts for Kinescope Anode (Approx.)
0	14000
140	12300

Fig. 1 - Deflection and High-Voltage Circuit for Kinescope RCA-16GP4.

enough so that series peaking is not necessary. With a sawtooth voltage of about 90 volts peak to peak, good performance can be obtained without either series or feedback peaking. With a small amount of feedback peaking, however, circuit efficiency can be slightly improved. Because excessive feedback peaking may cause instability or phase shift in the horizontal oscillator, it is advisable to determine the component values for the feedback circuit experimentally.

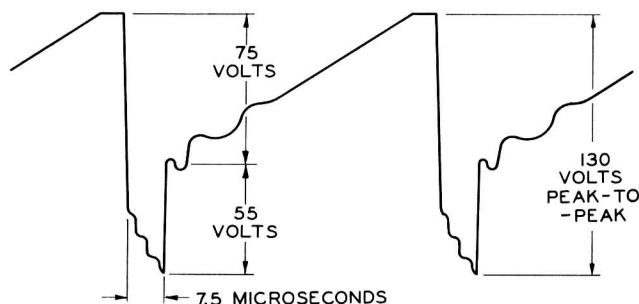

Fig. 2 - Waveform of Input to Grid-No.1 Circuit of RCA-6CD6-G Measured Across R1 in Fig. 1.

It is recommended that the 6CD6-G be protected against damage in the event that there is a loss of grid driving voltage. Protection can be obtained by selecting a cathode resistor of proper value. After the value of the screen dropping resistor which will keep the screen dissipation within its rating has been determined, the cathode resistor should be selected so that the tube plate dissipation is limited to 37.5 watts under no-drive-voltage conditions. Although the dc plate dissipation rating of the 6CD6-G is 15 watts, the tube is capable of withstanding up to 2-1/2 times this value for a short period. Because the plate dissipation will increase in proportion to the square of the plate current, it should be pointed out that the fuse in the plate supply circuit cannot be relied on to protect the tube against damage when there is a loss of driving voltage.

Width-Control Considerations

Fig. 1 shows two components functioning as width controls: width control RCA-208R1 which is connected to terminals 1 and 2 of the horizontal output transformer, and variable resistor R11 which is in series with the B supply for the deflection circuits. Either of these controls may be used. The use of width control RCA-208R1 permits changing the picture width approximately 10 per cent with a change in kinescope anode voltage of approximately 300 volts. The use of the 200-ohm variable resistor R11 provides a picture width change of approximately 15 per cent but produces an accompanying anode voltage change of approximately 15 per cent. In this type of circuit in which the vertical deflection power is the boosted voltage taken from the horizontal deflection circuit, picture height as well as width is changed when resistor R11 is varied. Consequently, where the initial



adjustment of aspect ratio is made, height control R20 should be used.

Resistor R11 also provides a means of compensating for the normally encountered changes in line voltage by controlling the power input to both deflection circuits. Under conditions of low line voltage when an increase in picture size is required, adjustment of R11 provides not only an increase in picture size, but also an increase kinescope anode voltage. Because R11 is not bypassed, the power dissipated in it is the product of the RMS current squared and the resistance. The RMS current, which must be measured with a thermal-type meter, is greater than the direct current.

Plate Pulse Voltage

During the retrace interval, a positive voltage pulse of 5500 volts is impressed on the plate of the horizontal-power-output tube. A portion of this pulse is fed back to the control grid through the grid-plate capacitance of the tube and associated wiring. This pulse opposes the action of the negative peaking pulse and, if it is too large, will prevent the maintenance of plate-current cutoff during the retrace interval. In order to minimize the effect of this feedback pulse, the wiring must be dressed to reduce grid-plate capacitance in the external circuit as much as possible. In addition, the value of the charging capacitor should be as large as practical so that the signal fed back through the interelectrode capacitance will have little effect upon the driving circuit.

If the plate-to-ground insulation or spacing of the 6CD6-G is inadequate, the 5500-volt pulse impressed on the tube plate during retrace will cause arc-over and corona. To minimize these undesirable effects, use soldered joints which are smooth and free from projecting points.

Damper-Tube Considerations

The cathode of the diode damper 6W4-GT receives a peak voltage of 2750 volts during the retrace interval. As it is not advisable to tie the heater to the cathode directly because of capacitive loading effects on the transformer, the heater is connected to a tap (terminal 4) on the transformer. This connection brings the peak heater voltage to 2400 volts and keeps the heater-cathode voltage to about 350 volts, a value well within the 2100-volt tube rating. The heater winding, of course, must be a separate one insulated for 3000 volts and should have an electrostatic shield between the primary and secondary windings to minimize power-line radiation. It is important that the socket also be capable of withstanding the 2750-volt pulse without breakdown or leakage.

Padder Capacitance

The total capacitance to ground of the heater winding, connecting leads, and padder capacitor should not exceed 300 micromicrofarads. The padder capacitor (C14) is across a portion of the horizontal-deflection transformer and, therefore, affects the natural period of the entire circuit. The value of this capacitor is chosen to adjust the duration and shape of the retrace surge so as to provide best performance particularly



with respect to scanning amplitude and high-voltage output. Its value, which is also affected by the capacitance-to-ground of the 6W4-GT heater winding, should be determined by trial during development work because the physical arrangement of the parts in the system affects the natural period. The optimum value is between 50 and 250 micromicrofarads. About 100 micromicrofarads is suggested as a suitable initial trial value. If the padder capacitor is placed across the width control, it will be equally as effective. The value, however, will have to be increased, but the voltage rating need only be 600 volts. A value of 0.005 microfarad is suggested as a suitable trial value.

Power Supply and Shielding

Series power feedback is used to increase the over-all circuit efficiency and reduce the B-supply voltage required. With a B-supply voltage of 350 volts, the boosted voltage is approximately 500 volts. The circuit arrangement also provides a current of approximately 18 milliamperes at 500 volts for the discharge and vertical-deflection circuits. Changes in the load on the 500-volt supply due to the discharge and vertical-deflection circuits will affect the distribution of currents in the horizontal output tube and diode damper, and will require a change in transformer ratio to maintain good linearity.

Shielding of the complete horizontal-deflection and high-voltage system is necessary because radiation of harmonic frequencies in the radio-frequency spectrum may interfere with nearby AM and FM receivers, as well as with rf and if circuits in the television receiver itself. This shielding must also isolate the horizontal oscillator and driver circuits from the horizontal-output and high-voltage circuits to prevent self-oscillation caused by stray capacitive coupling of the retrace pulse back to the oscillator. It is possible to use one ventilated metal enclosure for the entire horizontal system provided the enclosure is arranged with a partition to provide the necessary isolation of the oscillator. This arrangement eliminates the need for a separate shield for the oscillator and permits access to all tubes with the removal of a single shield.

High-Voltage Power Supply

The high-voltage output necessary for the kinescope anode is supplied by a voltage-doubling circuit. Before the circuit is put into operation, it is important to test the high-voltage capacitors for leakage at full rated working voltage. A typical regulation curve for this circuit is given in Fig.3.

Rectifier Filament Excitation

Because the components and performance requirements of individual circuit designs will vary, the designer should check the 1B3-GT filament temperature to be certain that the tube is being operated within its ratings. RCA Application Note AN-134 describes a method for making this measurement. When the high-voltage and scanning requirements are minimum, the design of the RCA-218T1 transformer permits adequate heating of the 1B3-GT filament. When the high-voltage and scanning requirements are high, it may be necessary to place a small resistor in series with the filament of each 1B3-GT to insure proper filament voltage.



Vertical Deflection Circuit

Vertical deflection power with ample reserve is obtained with the circuit shown in Fig.1. The pulse obtained from the conventional blocking-oscillator arrangement shown is sufficient to operate the discharge tube. A combined oscillator and discharge circuit may be used provided it produces a sawtooth with a peak amplitude of not less than 70 volts.

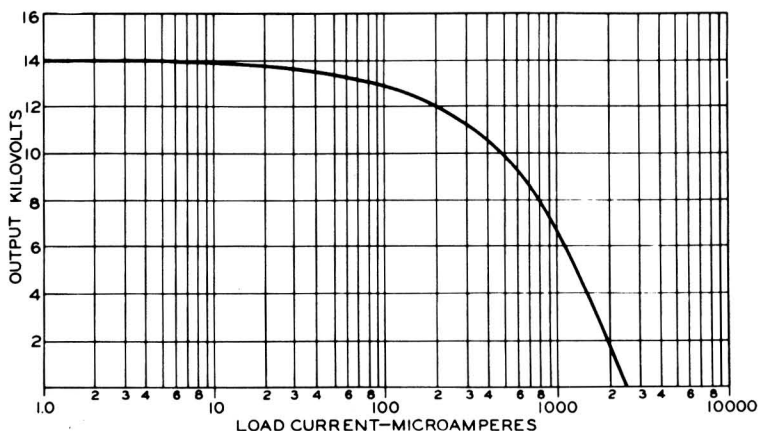

Fig. 3 - Measured Steady-Load Regulation Characteristic of Pulse-Operated High-Voltage Supply for the 16GP4 Kinescope.

Typical Operating Conditions for Deflection and High-Voltage Circuit of Fig. 1.

	6CD6-G	6W4-GT	6S4	
DC Plate Supply Voltage*	500#	350	485#	volts
Peak Plate Voltage	5000	-	1150	volts
DC Plate Current	92	110	17	ma
DC Grid-No.2 Current	15	-	-	ma
DC Grid-No.2 Voltage*	160	-	-	volts
DC Grid-No.1 Voltage*	-10	-	0	volts
Peak-to-Peak Grid-No.1 Voltage	130	-	108	volts
DC Cathode Voltage*	32	-	32	volts
Peak Cathode Voltage*	-	2750	-	volts

Total Current Drawn from Boosted Supply (approx.): 18 ma.

* With respect to B- (chassis).

350 volts from dc power supply plus dc boost supplied by 6W4-GT.

Devices and arrangements shown or described herein may use patents of RCA or others. Information contained herein is furnished without responsibility by RCA for its use and without prejudice to RCA's patent rights.